

INNOVATIVE  
TECHNOLOGY  
WORLDWIDE



NEUBERGER, INC.

## Operating and Maintenance Instructions

### For Portable & Installation Models: UN726/.0/.1/.2/.1.2/.3 Diaphragm Vacuum Pump Using Head Materials: AN, AT

#### Operating Instructions

**Note:** The following guidelines should be observed to promote safe and reliable operation of your KNF pump.

- KNF units are all 100% oil-free. No maintenance at all is necessary for the bearings and NO lubrication should be done. All bearings are sealed and permanently lubricated. For repair service, call KNF Customer Service.
- Be sure that the available electric power matches specifications marked on the motor. Serious damage may occur to the motor if connected to an improper voltage. All KNF units should be grounded using the provided brass screw or grounded 3-prong plug. In the event of an electrical short circuit, grounding reduces the risk of electric shock by providing an escape wire for the electric current.
- The pump should be placed where the surrounding temperature remains between 40°F and 104°F (5°C and 41°C). This is particularly important when the unit is installed in a confined space where heat may build up during operation.
- Standard models are designed to *start against atmospheric pressure only, not under load (Pressure or vacuum)*. Care must be taken to eliminate load when pump is turned off for any reason. Optional modifications for the pump to start under load may be available for certain models.
- Use this pump only to pump air or gas, not liquids or particulates. *Damage to the pump or loss of performance can occur if liquids or particulates enter the system.*
- Always install the pump in such a location that it is protected from direct (or indirect) moisture contact.
- Avoid operating the pump in very dusty conditions. If necessary, install an inlet filter and change it frequently.
- If flow is throttled or restricted for any reason, care must be taken to avoid exceeding the maximum continuous operating design pressure of the unit.
- Be sure that the pump is installed at the highest point within the system to prevent possible liquid condensate from entering the unit.
- To avoid personal injury, remove any protective plastic plugs supplied prior to applying power to the motor.
- Run the pump for a few minutes to warm it up before handling saturated or nearly saturated vapors.
- After use, let the pump run for about 2 minutes in air before switching it off, to purge out droplets of liquid that may have formed on the inside of the pump. This prevents crystallization

and/or absorption of liquids by the pump materials.

- Do not thread metal fittings into Kynar-coated (TT) pump heads. Use plastic or nylon only.

#### Troubleshooting

**Warning!:** AC motors are thermally protected and will automatically restart unexpectedly when the overload device resets. - Don't pump flammable or explosive gases or operate this pump in an atmosphere containing flammable or explosive gases.

Your KNF Pump should perform to specifications for years if the simple operating instructions and precautions are observed. If you experience a problem and suspect the pump, try these simple checks prior to calling for assistance:

- Check that all system interconnections are gas-tight and head screws are snug. Do not overtighten screws.
- Remove the head assembly as described in "Changing the Diaphragm and Valves". Look for any foreign matter; usually bits of Teflon® tape or particulates carried into the valve system or crystallized material from previously pumped vapors. All of the above must be cleared out and reassembled with clean parts.
- If pitting of the pump parts or tearing of the diaphragm is observed, it is possible that the gas/vapor being pumped is capable of dissolving the wetted parts of the pump.  
Chemical resistance charts should be consulted for compatibility with wetted parts. Generally, replacement of the diaphragm and reed valves will restore the pump to operating specifications if there is no pitting or debris in the valve seat area.
- Check that power is being supplied to the pump from the power source and the pump switch is in the on position.

#### Spare Parts Kits (One kit per head)

Kit consist of:

Qty	ID#	Description
1	G	Molded Diaphragm
2	Q	SS Reed Valve
1	P	SS Screw M3
2	P	SS Washer
1	P	SS Hexagon Nut
1	V	Head Gasket

#### For Model N726AN

Order Kit Number: K726-1ANA

#### For Model N726.3AN

Order Kit Number: K726-9ANA

#### For Model N726AT, N726.3AT

Order Kit Number: K726-1ATA

**Note:** Above kit is to renew one head only. Two kits are required to renew a twin-head pump (.1.2/.3 models).

#### Limited Warranty

KNF NEUBERGER, INC. (KNF) warrants to buyer that its products will be free from defects in material and workmanship under normal and appropriate use, and agrees to repair or replace any of its products without charge for parts or labor within one year from the date of shipment to the original purchaser.

#### Products to be evaluated for warranty coverage:

Determination of coverage under this warranty is the sole responsibility of the manufacturing engineering representative of KNF. This determination will frequently require the return of the product to KNF. All product returns will be handled in accordance with KNF's product return policy. KNF reserves the right to inspect custom installations and devices that use KNF products as part of the warranty evaluation process.

This warranty does not cover any misuse, negligence, deterioration by chemical action, unauthorized repair or alteration in any way, inappropriate handling or storage that in our judgement caused the product failure. KNF shall not be liable for any inconvenience, loss of use, or any consequential loss, damage or injury arising from any cause whatsoever. No employee, agent or representative of KNF shall have any right or authority to vary or alter the terms of this warranty. This warranty gives you specific legal rights, and you may have other rights which vary from state to state.

#### Limitations

KNF offers engineering and technical assistance to support the application and selection of our products.

**Except as otherwise agreed to in writing, it is expressly understood that this warranty is in lieu of any and all other warranties, whether expressed or implied, with respect to the goods sold, including any warranty of merchantability and fitness for a particular purpose. Sole responsibility or liability of KNF shall be to replace any products or parts thereof which shall not conform to such warranty, provided that the products are used in accordance with KNF specifications. Customer is responsible for determining the suitability of our products for customer's use or resale, or for incorporating them into objects or for applications which customer designs, assembles constructs or manufactures.** Please call our Technical Sales Department for further information.

#### Return Requests / Inquiries

Direct all warranty and repair requests to KNF Customer Service Department for instructions before returning any unit for repair or evaluation. We will fax you a "Return Instruction Sheet" for guidance on the proper marking, packing and documentation requirements.

Important information conforming to the "Right To Know" act, such as a Material Safety Data Sheet may be required.

**Products shipped to KNF must have a Return Materials Authorization Number (RMA) file number marked on the outside of the package, otherwise they will be refused by our receiving department.**

## Changing the Diaphragm and Reed Valves

### Notes:

1. If your model Number begins with MPU, PU or PJ, contact KNF Customer Service for the proper Parts Kit, as the contents may differ from those kits listed above.
2. For twin-head pumps, always change the diaphragm and reed valves in both heads at the same time. Follow the below procedures for each head.

### Materials needed:

- Proper replacement kit(s)
- Roll of Teflon® tape (available at most hardware stores)
- Felt marking pencil

### Tools Required:

- 3 mm Allen key wrench
- 4 mm Allen key wrench
- 20 mm open-end wrench
- Small slotted-head screwdriver
- Medium slotted-head screwdriver

### Changing the Diaphragm:

1. Disconnect the pump from electrical power. For parallel and two-stage models, make a sketch of the position of interconnecting tubes and fittings. Remove them by undoing nuts with the 20 mm wrench, or loosening hose clamps, and carefully pulling tubing from fittings.
2. Mark the relative positions of the head plate **A** and crankcase housing **B** with a line using a marker for ease of reassembly later. Note that .1.2 and .3 models head orientation is different from the single head model shown on the diagram.
3. Undo the 4 socket head cap screws **C** and lift off the head plate **A**.
4. Remove the 4 pan head screws **J** and remove the housing lid **K**.
5. Unscrew the old diaphragm **G** by turning it counterclockwise using both hands. Do not use tools. IMPORTANT — Take care not to lose any spacers **H** positioned between the diaphragm stud and connecting rod **L**, as the exact quantity must be reassembled later for proper pump operation.
6. Place *the same quantity of spacers* removed in step 5 above onto the threaded stud of the new diaphragm. Carefully screw the new diaphragm into the connecting rod **L**. NOTE: Tighten firmly using both hands only. DO NOT use tools.

### Changing the Reed Valves:

1. Dismantle the head **A** as outlined above. In addition, remove the socket head cap screws **S**, remove the head lid **T** and head gasket **V**.
2. Loosen the single stainless steel pan head screw **P**, washers and nut, and remove the two stainless steel reed valves **Q**.
3. Lightly clean the valve seat area on the headplate **A** of any debris or deposits with fine steel wool. This area must be clean and smooth, without pits or scratches. Do not scratch the head plate.
4. Lay the two replacement reed valves **Q** on a clean, flat surface to determine the direction of any slight bend.
5. Lay the replacement reed valves **Q** in place, center bowed out, (see inset:

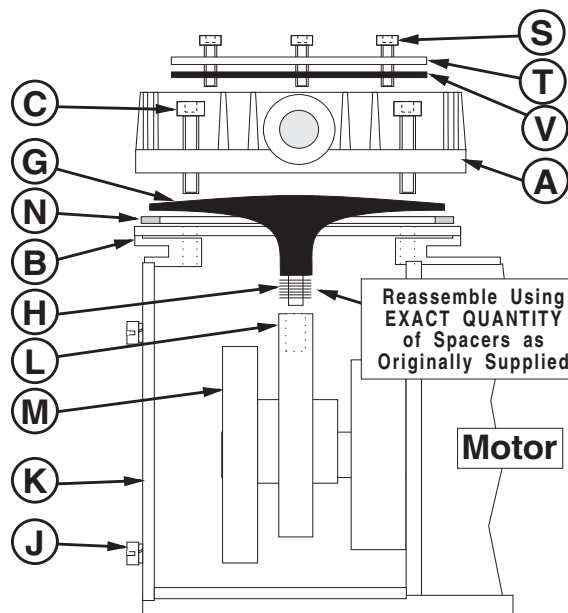

Reassemble Using EXACT QUANTITY of Spacers as Originally Supplied

Motor

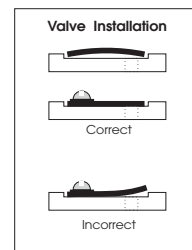
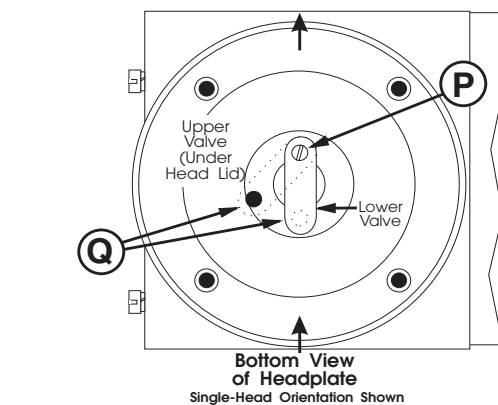

Valve Installation

## UN726AN, AT

### Head Interconnections

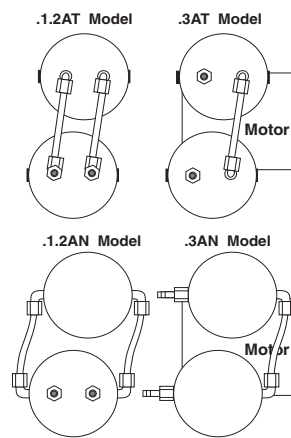

### Wiring Diagrams

For Single Head Pumps

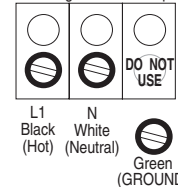

For Twin Head Pumps

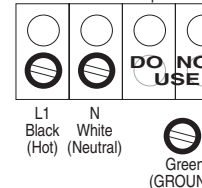

valve installation) and tighten the pan head screw **P**, both washers and nut. **NOTE:** Make sure that the reed valves lay straight and smooth with clearance from the recessed edge to prevent sticking. If a reed valve curves slightly away from the valve hole, remove the screw, flip the reed valve over and re-install.

6. Turn the counterweight **M** until the diaphragm is in mid-position (flat across). Carefully center the diaphragm over the compressor housing **B**, or over the head spacer ring **N**. *Note: Only double-head pumps are supplied with a head spacer ring.*
7. Place the head plate **A** on top of the diaphragm, lining it up with the compressor housing markings you made in step 2. Note that .1.2 and .3 models head orientation is different from the single head model shown on the diagram.
8. Tighten the 4 socket head cap screws **C** uniformly in a crisscross pattern.
9. Reassemble lid **T** using a new gasket **V** and and the socket head cap screws **S**, tightening uniformly in a crisscross pattern.
10. Check that the pump runs freely by turning the counterweight **M** by hand.

11. Carefully apply two layers of Teflon® tape around each fitting thread. *Do not hang tape over edge of fitting.* Reinstall the head connecting tubing and fittings as previously sketched in step 1 above. *Do not use excess tape or substitute any other type of tape. Excess tape may get carried into the valves.* Ensure that the compression rings (ferrules) are correctly positioned under the union nuts before tightening the interconnection fittings.

**Note:** Should you need to send a KNF pump to our factory for repairs, please be sure to read the instructions in the Limited Warranty section with regard to obtaining an RMA (Return Materials Authorization) number prior to shipment.

### Individual Parts: (per head)

ID#	Description
A	Headplate
C	Socket Screw (4 per head)
G	Diaphragm
H	Diaphragm Spacers (Note 1)
S	Socket Screw (8 per head)
T	Head Lid
V	Head Gasket
Q	Reed Valves (2 per head)

### Notes:

1. Use same quantity as originally supplied.
2. Contact KNF Customer Service for ordering information.

### For Service or Parts, CONTACT: KNF NEUBERGER, INC.

Two Black Forest Road  
Trenton, New Jersey 08691-1810  
Fax: 609-890-8323 · Phone: 609-890-8600